

PRELIMINARY



REGENERATIVE GRID SIMULATOR MODEL 61800 SERIES

Market demand for Distributed Resource (DR) products such as PV inverters and wind energy systems is steadily growing as the world strives for clean renewable energy sources. This demand has created a need for rigorous regulation testing to standards such as IEEE 1547 / IEC 61000-3-15 / IEC 62116 ensuring proper and safe operation of on-grid products. It has become critical to manufacturers to conduct these tests to prove compliance and to relieve product liability concerns. Chroma's new 61800 family of Grid Simulators has been designed to fulfill these test requirements by providing a full 4 quadrant, fully regenerative, grid simulator with advanced features for compliance, safety and product verification testing.

The 61800 regenerative grid simulator allows users to vary relevant parameters in order to simulate real world grid environments and conditions. Supported variations include frequency, phase angle, voltage amplitude, voltage drops in either single or three phase modes. Unbalanced three phase conditions can easily be simulated. And most importantly, the regenerative feature of the 61800 grid simulator provides an effective energy saving method since energy generated by unit under test is fed back to the grid instead of dissipated as heat during operation.

The 61800 grid simulator could also meet test requirements with smart grid and EV related test applications, such as Vehicle to Grid (V2G) and Energy Storage System (ESS) testing.

The 61800 regenerative grid simulator is not only limited to product development during R&D. Its extensive features are also valuable during design and quality verification as well as throughout various production stages. Using state-of-the-art digital control technology the 61800 can deliver up to 300VAC at output frequencies ranging from 30Hz to 100Hz. The AC+DC feature allows for applications which require a DC offset bias.

The 61800 series is also able to provide precision measurements such as RMS voltage, RMS current, true power, power factor, current crest factor and many others. By applying advanced DSP technology, the 61800 can easily simulate power line disturbance (PLD) using LIST, PULSE and STEP modes. Additional features such as the waveform synthesis function allows users to program various distorted harmonic waveforms which are required by some regulatory standards. GPIB (IEEE488.2), RS-232, USB and Ethernet interface are available to control the 61800 grid simulator remotely.



Regenerative Grid Simulator

MODEL 61800 SERIES

Key Features

- Output Power
61845 : 45kVA
61860 : 60kVA
- Output Voltage: 0-300V
- Output Frequency: DC, 30Hz-100Hz
- User selectable single phase or three phase output
- Full 4 quadrant, fully regenerative up to 100% of output current rating
- Specifically designed for PV inverter, Smart Grid and EV related test applications
- Programmable slew rate settings for voltage and frequency
- Programmable voltage and current limits
- Turn on, turn off phase angle control
- LIST, PULSE, STEP mode functions for testing Power Line Disturbance (PLD) simulation
- Voltage dips, short interruption and voltage variation simulation
- Harmonics, inter-harmonics waveform synthesizer
- Comprehensive measurement capability, including current harmonics
- Analog programmable interfaces
- Remote interface: GPIB, RS-232, USB and Ethernet
- Parallel output for higher power applications (Three phase only)

$$60\text{kVA} \times 3 = 180\text{kVA}$$



Chroma

FUNCTIONS AND APPLICATIONS

The 61800 Regenerative Grid Simulator is a full 4 quadrant, full regenerative, AC power supply designed for common electrical product testing such as home appliances, and industrial electronics needing a programmable input source. In addition, the 61800 is design to simulate grid characteristics for testing PV inverter and on-line UPSs. As shown below, power can be both sink and source from the UUT seamlessly for to support different types of applications. In cases where the UUT sources current a detection circuit will sense the excess power and recycled it back to the grid.

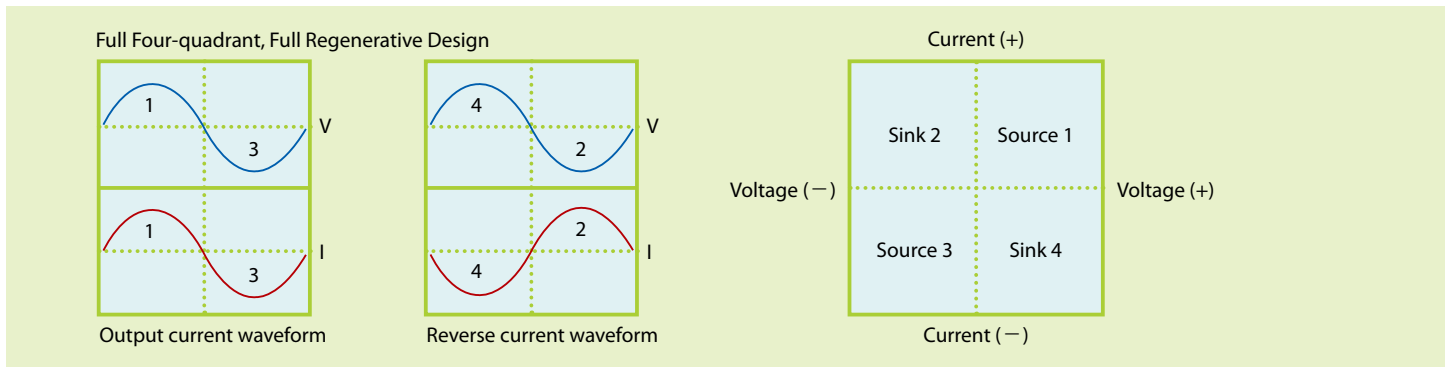
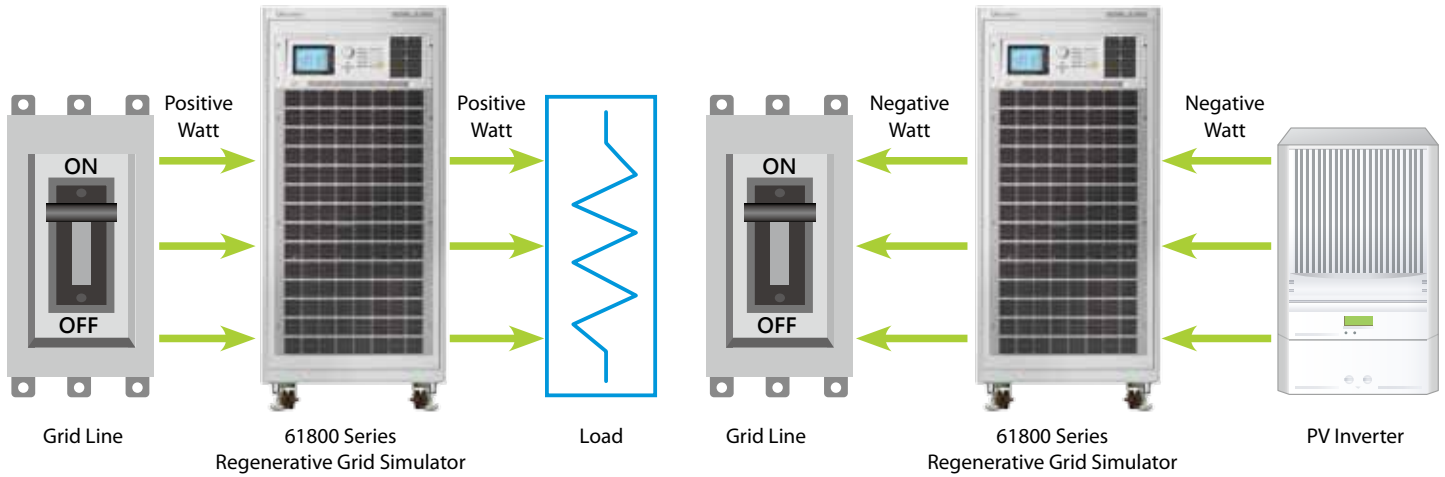

In addition to supply clean, precise and stable AC voltage for regular applications, the 61800 is capable of simulating various types of distorted voltage waveforms and transient conditions required by product validation testing. These are accomplished as shown below using built-in programmable waveform functions such as LIST/STEP/PULSE modes. The STEP and PULSE functions allow users to perform single or continuous step changes of output voltage. While the LIST mode is a more versatile function as it allows users to compose complex waveforms of up to 100 sequences. Voltage waveforms required by immunity specifications such as IEC 61000-4-11 (short interruption and voltage dropout) can easily be achieved by the 61800 Regenerative Grid Simulator.



STEP Mode

PULSE Mode

LIST Mode

The SYNTHESIS function allows users to create periodic harmonic voltage waveforms of up to 40 orders based on a 50/60Hz fundamental frequency. The INTERHARMONIC function allows users to perform frequency sweeps ranging from 0.01Hz to 2400Hz on top of the 50/60Hz fundamental frequency. This special function assists users in locating the resonance points.

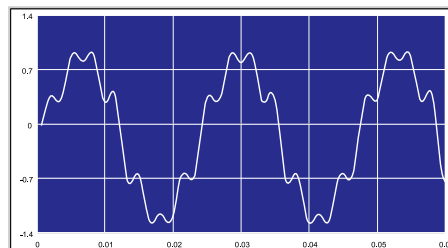

Harmonics Waveform

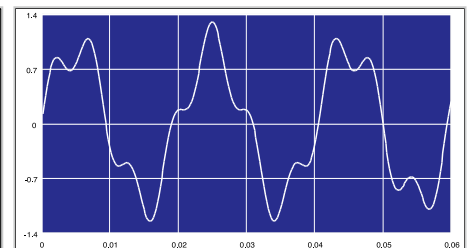

Interharmonics Waveform

Implement for Micro Grid Testing

The 61800 Regenerative Grid Simulator is capable of simulating various test conditions such as voltage distortion, frequency variation, etc., in order to meet the Micro Grid test requirements. Most importantly, the regenerative feature of 61800 series product could sink the power generated by the Discrete Generator (DG) on the micro Grid and feed the power back to the main grid. The input side of 61800 series product has specifically designed to be isolated from the main grid. Hence additional isolation for Discrete Generator (DG) on Micro Grid is not required.

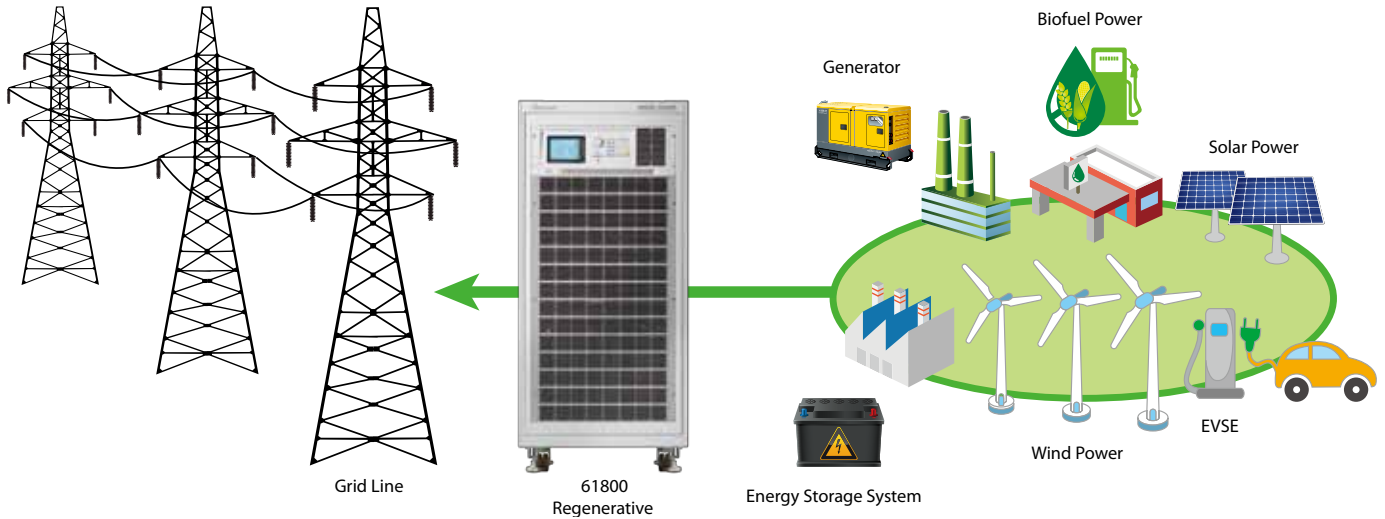

Implement for Grid Tied DG Regulations Testing

The 61800 series Regenerative Grid Simulator is capable of meeting the following regulations designated for Grid Tied Discrete Generator testing such as IEEE 1547 / IEC 61000-3-15 / IEC 62116 :

- ✓ Voltage Abnormality Test
- ✓ Frequency Abnormality Test
- ✓ Anti-islanding Test
- ✓ Low Voltage Ride Through Test
- ✓ Immunity Test (IEC 61000-4-11/-4-34)
- ✓ Limit Test (IEC 61000-3-2/-3-3)

Effective Energy Saving Solution

The 61800 Regenerative Grid Simulator provides an effective energy saving solution as the energy generated by Discrete Generator (DG) is fed back to the grid instead of dissipated as heat during operation.

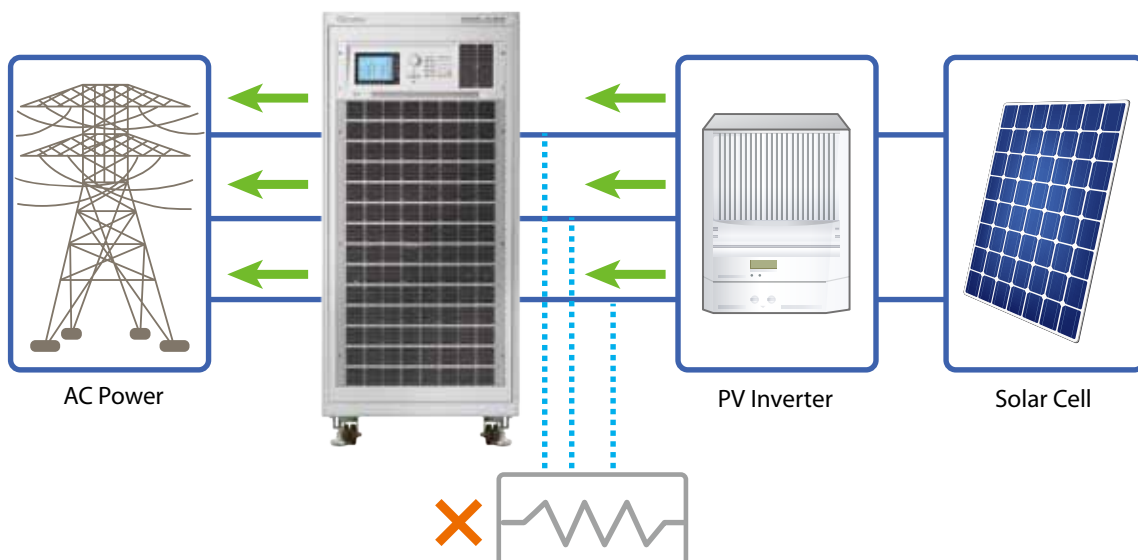

Implement for Low Voltage Ride Through (LVRT) Testing

The Low Voltage Ride Through (LVRT) function of grid tied PV inverter has clearly defined when abnormality occurs on the main AC grid (such as: voltage drop), the PV inverter must remain operable and sustain the main AC grid for certain specific time period, for instance: the BDEW standard requires the PV inverter to remain operable and delivering reactive power for at least 150ms when the grid voltage has dropped to 15% of the nominal value.

The 61800 Regenerative Grid Simulator is fully capable of meeting the LVRT test requirements, as user could program the required transient test conditions by implement the LIST mode function with minimum time resolution setting of 0.1ms. Moreover, user could also study and evaluate the impact on PV inverter performance due to grid line voltage distortion, by implementing the harmonic synthesis function of 61800 series product. The frequency resolution of 61800 is 0.01Hz which has met the BDEW requirement.

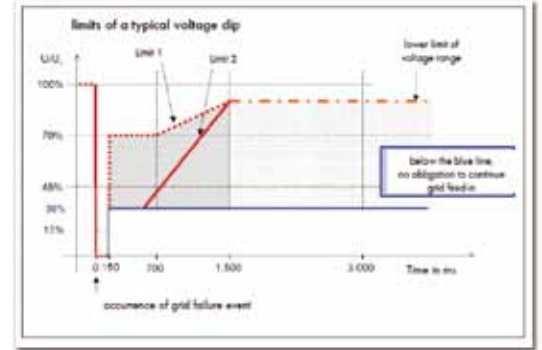

Test number	U/UN	LVRT duration (ms)
1	≤ 0.05	≥ 150
2	0.2 - 0.5	≥ 550
3	0.45 - 0.55	≥ 950
4	0.7 - 0.8	≥ 1400

Implement for Anti-islanding Testing

By incorporating the 61800 Regenerative Grid Simulator with the 8000 ATS and A800067 RLC load, the test system is capable of meeting IEC 1547 / IEC 62116 test requirements for Anti-islanding test.

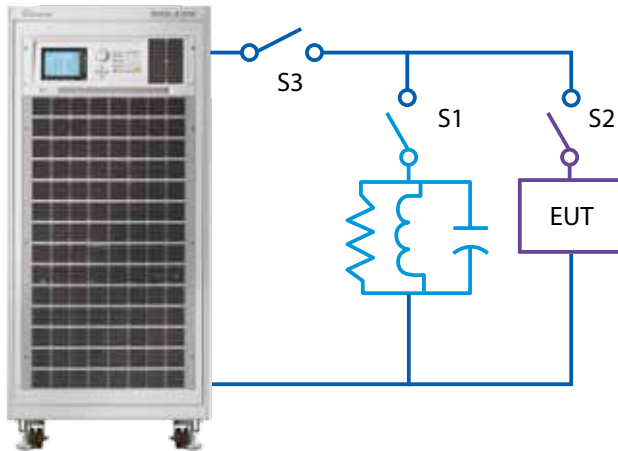

61800 Series Regenerative Grid Simulator



8000 Automatic Test System

61800 Series Regenerative Grid Simulator

A800067 RLC Load

SOFTPANEL

The 61800 Softpanel is a Graphical User Interface specifically designed to provide users with an easy to use interface for configuring the instrument. The self explanatory graphical panels provide control of the 61800 with just a few clicks of a button. The Softpanel is also equipped with data recording functions allowing multiple measurements to be recorded and saved simultaneously.



Main Operation Menu

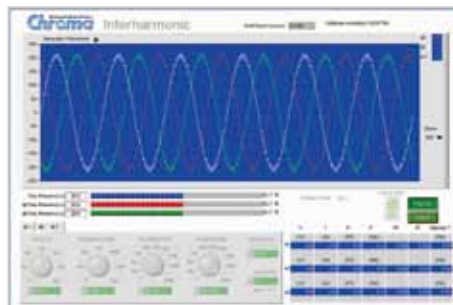

Interharmonic Test

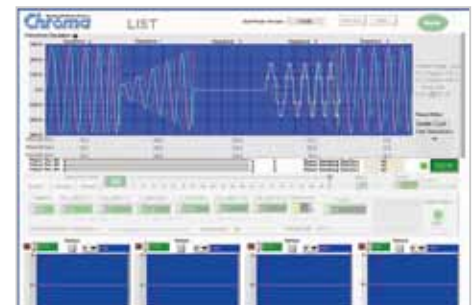

Transient Voltage Programming



Voltage DIP, Short Interruption, Variation Test



Distorted Waveform Editor



Recording Function

PANEL DESCRIPTION

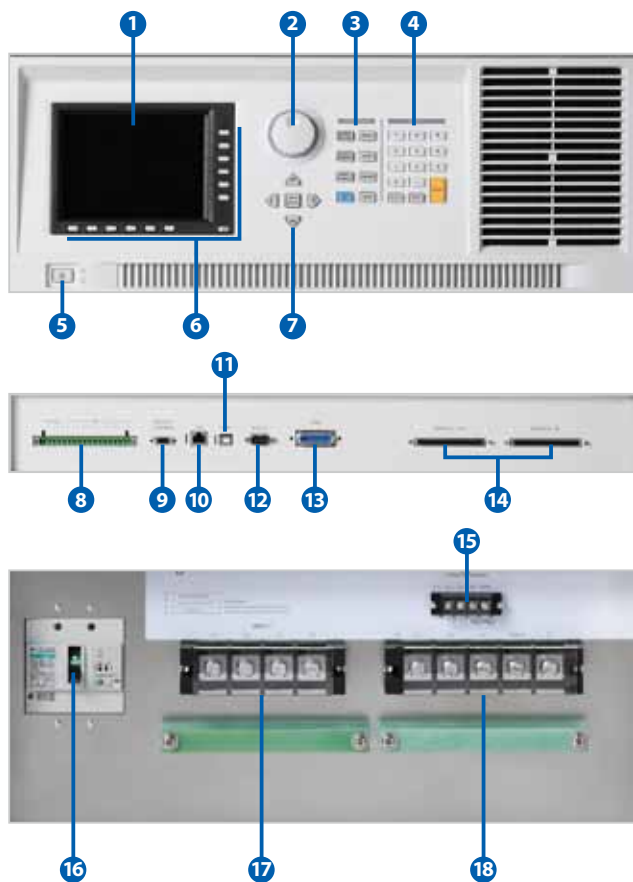

- 1. LCD Display**
- 2. Rotary Knob:**
For adjusting voltage, frequency and other parameter setting
- 3. Function Key:**
Hot keys for quick parameter setting
- 4. Numeric Key:**
For data entry
- 5. On/Off Power Switch**
- 6. Soft Keys:**
Supports menu driven interface
- 7. Cursor movement Keypad**
- 8. External V reference/TTL I/O Port:**
External analog signal for voltage control and signals for system integration
- 9. Remote Control Port used for handheld controller**
- 10. LAN (Ethernet) Port**
- 11. USB Interface**
- 12. RS-232 Interface**
- 13. GPIB Interface**
- 14. Master/Slave parallel port :**
Used when paralleling more than one unit
- 15. Remote Sense:**
For line voltage compensation
- 16. Main Power Breaker:**
NFB with leakage current detection ability
- 17. Input AC power terminal**
- 18. Output Terminal**

ORDERING INFORMATION

61845 : Regenerative Grid Simulator 45kVA

61860 : Regenerative Grid Simulator 60kVA

A618001 : Softpanel for 61800 Series

A618002 : Terminals for parallel connecting

PRELIMINARY SPECIFICATIONS

Model	61845	61860
AC Output Rating		
Output Phase	1 or 3 selectable	1 or 3 selectable
Max. Power	45kVA	60kVA
Per Phase	15kVA	20kVA
Voltage		
Range	0~300V _{LN} /0~520V _{LL}	0~300V _{LN} /0~520V _{LL}
Accuracy	0.2%+0.2%F.S.	0.2%+0.2%F.S.
Resolution	0.1V	0.1V
Distortion *1	< 0.5% @ 50/60Hz < 0.8% @ 30Hz~100Hz	< 0.5% @ 50/60Hz < 0.8% @ 30Hz~100Hz
Line regulation	0.1%	0.1%
Load regulation	0.2%	0.2%
Max. Current (1-Phase Mode)		
RMS	225A	300A
Peak	675A	900A
Max. Current (each phase in 3-Phase Mode)		
RMS	75A	100A
Peak	225A	300A
Frequency		
Range	30Hz ~ 100Hz	30Hz ~ 100Hz
Accuracy	0.01%	0.01%
DC Output (1-Phase Mode) *2		
Power	22.5kVA	30kVA
Voltage	300V	300V
Current	112.5A	150A
DC Output (3-Phase Mode)		
Power	7.5kVA	10kVA
Voltage	300V	300V
Current	37.5A	50A
Harmonics Synthesis Function		
Harmonics range	up to 40 harmonics order @ 50/60Hz fundamental frequency	
Regenerative Function to Grid Line		
Current Harmonic Distortion	5% (Typical)	
Power factor	0.95 (Typical)	
Input Rating		
Voltage Operating Range *3	3Ø 200~220V ± 10%V _{LL} , 47~63Hz 3Ø 380~400V ± 10%V _{LL} , 47~63Hz 3Ø 440~480V ± 10%V _{LL} , 47~63Hz	3Ø 200~220V ± 10%V _{LL} , 47~63Hz 3Ø 380~400V ± 10%V _{LL} , 47~63Hz 3Ø 440~480V ± 10%V _{LL} , 47~63Hz
Current	190A Max./Phase (3Ø 200~220V ± 10%V _{LL}) 100A Max./Phase (3Ø 380~400V ± 10%V _{LL}) 87A Max./Phase (3Ø 440~480V ± 10%V _{LL})	250A Max./Phase (3Ø 200~220V ± 10%V _{LL}) 130A Max./Phase (3Ø 380~400V ± 10%V _{LL}) 115A Max./Phase (3Ø 440~480V ± 10%V _{LL})
Power factor	0.99 (Typical)	
Measurement		
Voltage		
Range	0~300V	
Accuracy	0.2%+0.2%F.S.	
Current		
Range (peak)	225A	
Accuracy (RMS)	0.4%+0.3%F.S.	
Accuracy (peak)	0.4%+0.6%F.S.	
Power		
Accuracy	0.4%+0.4% F.S.	
Others		
Efficiency	80% (Typical)	
Protection	OVP, OCP, OPP, OTP, FAN	
Safety & EMC	CE (include EMC & LVD)	
Dimension (H x W x D)	1740 x 780 x 1000 mm (include wheel set)	
Weight	850kg	

Note*1 : Maximum distortion is tested on output 250V with maximum current to linear load

Note*2 : The DC function is mainly intended as DC offset for AC+DC output voltage function

Note*3 : Must be specified at time of order. All inputs are L-L, 3Ø, 3 wire+GND

All specifications are subject to change without notice.

Developed and Manufactured by :

HEADQUARTERS
CHROMA ATE INC.
66 Hwaya 1st Rd., Kueishan
Hwaya Technology Park,
Taoyuan County 33383,
Taiwan
Tel: +886-3-327-9999
Fax: +886-3-327-8898
http://www.chromaate.com
E-mail: info@chromaate.com

CHINA
CHROMA ELECTRONICS
(SHENZHEN) CO., LTD.
8F, No.4, Nanyou Tian An
Industrial Estate, Shenzhen,
China PC: 518052
Tel: +86-755-2664-4598
Fax: +86-755-2641-9620

JAPAN
CHROMA JAPAN CORP.
472 Nippa-cho, Kouhoku-ku,
Yokohama-shi, Kanagawa,
223-0057 Japan
Tel: +81-45-542-1118
Fax: +81-45-542-1080
http://www.chroma.co.jp
E-mail: info@chromaate.com

U.S.A.
CHROMA SYSTEMS
SOLUTIONS, INC.
19772 Pauling, Foothill Ranch,
CA 92610
Tel: +1-949-600-6400
Fax: +1-949-600-6401
http://www.chromausa.com
E-mail: sales@chromausa.com

EUROPE
CHROMA ATE EUROPE B.V.
Morsestraat 32, 6716 AH Ede,
The Netherlands
Tel: +31-318-648282
Fax: +31-318-648288
http://www.chromaeu.com
E-mail: sales@chromaeu.com

Worldwide Distribution and
Service Network